

# M-60AX

800W X 600H mm (Aluminum Arch) (Standard)

- Innovative **AUTO-FEEDING** Function : to press the "INSERT" button, the strap will be fed automatically and be ready for the first strapping cycle application.
- Auto positioning and retry function : to secure the strap goes to its' proper position and every cycle is accurate and efficient.
- **JAM-FREE** function : auto strap loops ejecting design to correct strapping problems.
- Electronic tensioning : to get optional 5-75 kg tension strength by adjusting the tension knob.
- Internal foot pedal system : strap cycle will be completed more easily
- Equipped with patent aluminum alloy arch modular design : it is easy to assemble, disassemble, change size economical, no arch motor is required (3rd Generation)
- Strap cycle can be done by a start switch, table ball switch and foot pedal bar.
- with motor auto-stop function.
- Lift type top cover allows convenient maintenance.

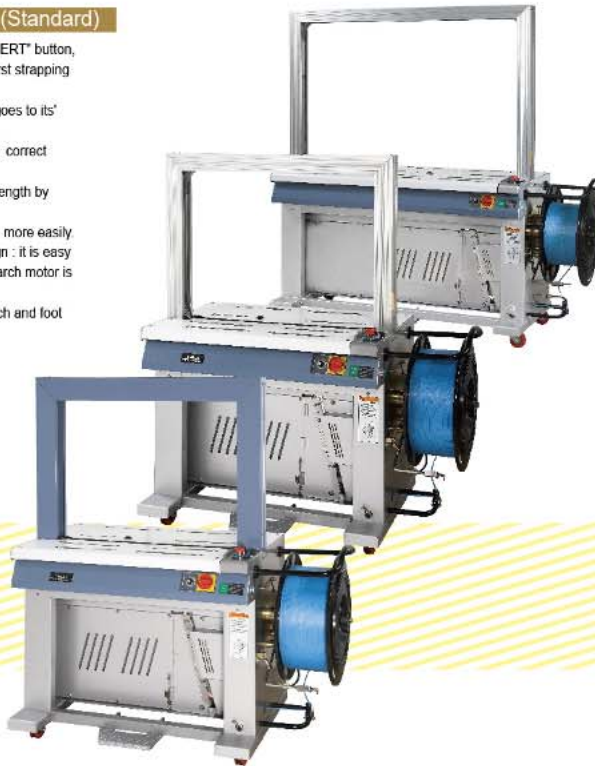

## M-60AX M

Arch: 600W x 400H mm (Standard)

- The medium size of frame of M-60AX is designed to strap tiny boxes, mails, newspaper and magazines.
- It is suitable to operate in your offices, post offices and so on. It is suitable for strapping 6 mm of strap.
- The machine is equipped with auto-feeding function, instant heater function, internal foot pedal system and low noise operation...etc. The main purpose is to make the operation more easily.
- with **CKD frame and powder painting on frame & iron arch cover.** Powder painting is only suitable for M-60AX & M-60AXM. Standard Color on frame (Silver) and front control panel (Pigeon Blue)
- The other details are as same as M-60AX.

# M-60AX N

The new M-60AXN is a modern concept of automatic strapping machine with the upgrade Auto-feeding system for a dependable and reliable strapping application



- 2 front doors type
- Upgrade **AUTO-FEEDING** system: to upgrade the Auto-feeding system and the Forwarding & Reversing system. The purpose is to speed up the strapping cycle speed. Each cycle is accurate and efficient.
- **JAM-FREE** function: auto strap loops ejecting design to correct strapping problem
- Fixed foot pedal switch long side machine
- Equipped with patent aluminum alloy arch modular design: it is easy to assemble, disassemble, change size economical, no arch motor is required. (3rd Generation)
- Strap cycle can be done by a start switch, table ball switch and foot pedal bar.
- Lift type top cover allows convenient maintenance.
- Iron arch cover (Optional)

## M-60AX N5

Big Arch (1250W x 500H mm) (Iron Arch Cover) (Standard)

- Available for 5 mm P.P. strap
- Moveable arch bandway design
- DC brushless motor technology
- Speedy, stable and low noisy design
- Retractable coil holder for easy coil loading
- Fixed foot pedal switch long side machine
- Humanized design of control panel

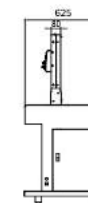
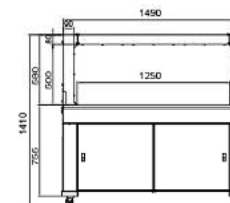

## M-60AX NM

Arch: 600W x 400H mm (Standard)

- Single front door type
- The medium size of frame is suitable to strap the tiny boxes, mails, newspaper and magazines.
- Upgrade **AUTO-FEEDING** system: to upgrade the Forwarding & Reversing System. The purpose is to speed up the strapping cycle speed. Each cycle is accurate and efficient.
- Fixed foot pedal switch long side machine
- Iron arch cover (Optional)
- The details are as same as M-60AXN.





# M-60AX PR-2HT

Power Roller Table with Arch 750W x 575H mm (Standard)

- Power Roller Table: it is easy to maintain by raised-up top cover.
- Equipped with two photocells (2HT), safety 24V and PLC electric control system.
- User can choose to strap for 1 strap, 2 straps or none strap via control panel, it depends on user's choice.
- Supply a circuit to combine input & output of conveyors.
- 110V/ 220V single phase are available.
- The other details are as same as M-60AXPB-2HT

# M-60AX PR-3HT

Power Roller Table with Big Arch 1150W x 375H mm

- Suitable for various heavy products such as tiles, bricks and so on.
- 3 photocells
- Red/Yellow/Green warning lamp and buzzer
- Iron cover arch (Standard)
- The other details are as same as M-60AXPB-2HT.
- Brushes on the top and 2 sides of iron arch cover. (Optional)
- Embossed process on power rollers surface (Optional)



# M-60AX 900D

- Single front door type
- Retractable coil holder for easy coil loading
- Fixed foot pedal switch long side machine
- 3 pieces of L type of carton holders on the top table to fix the strapping position
- Available for strapping money, mails and tiny boxes, etc.
- Without any free rollers on the top table
- Iron arch cover (Optional)
- #32 tiny slide table to strap the tiny packages (Optional)
- Equipped with brushes on the top and 2 sides of iron arch covers to fix the strapping position. (Optional)



# M-60AX 940

- Retractable coil holder for easy coil loading
- Iron arch cover (Optional)



# M-60AX 940D

- 2 front doors type
- Retractable coil holder for easy coil loading
- External type foot pedal switch
- Iron cover arch (Optional)
- Equipped with brushes on the top & 2 sides of iron arch covers to fix the strapping position. (Optional)





# M-60AX PB-AP-2HT

- Equipped with light duty air pressure. (Pressure: 6 kg/cm<sup>2</sup>(Bar), Cylinder: inner Ø50 mm, Stroke: 550mm).
- Suitable for strapping cartons, paper boards or pre-transported formative cases, etc.
- According to requirements, additional functions such as to delay the strapping are available (Optional)
- Arch size is optional to fit various size of package.
- The other details are as same as M-60AXPB-2HT.

# M-60AX PB-2HT



- Power Belt Table (with 8 timing Belts).
- Equipped with two photocells(2HT), safety 24V and PLC electric control system.
- User can choose to strap for 1 strap, 2 straps or none strap via control panel, it depends on user's choice.
- Supply a circuit to combine input & output of conveyors.
- 110V/220V single phase are available.
- Easy maintenance by raised-up top cover.
- Patent new aluminum arch with iron arch cover (Standard)
- The other details are as same as M-60AX.

## OPTION

1.

THE SPEED OF POWER TABLE IS ADJUSTABLE.

2.

IT IS EQUIPPED WITH "TABLE AUTO-STOP" PHOTOCELL.

3.

IT IS AVAILABLE TO CHANGE THE ARCH SIZE.

4.

THE HEIGHT OF POWER TABLE IS ADJUSTABLE.

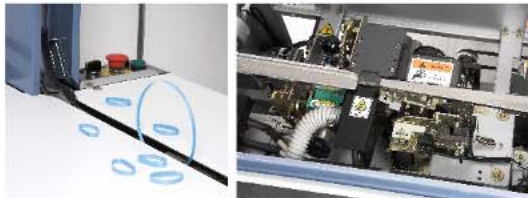

- Automatic Looping System : Jam-Free function. It's designed to correct strapping problem.
- Special treated slide table and looping.

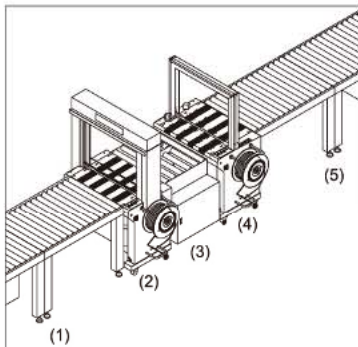

- The machines can be well connected with input power roller(belt) conveyors, 90° degree turntable and output power roller (belt) conveyors, etc.

- Input power roller conveyor.
- M60AXPB-AP-2HT fully-auto strapping machine.
- Power roller type 90° turntable.
- M-60AXPB-2HT fully-auto strapping machine.
- Output power roller conveyor.



International Patent reserved reproduced must be investigated.

# M-60 AX SERIES

Model	M-60AX	M-60AXM	M-60AXN	M-60AXNM
Arch Size (WxH)	800 x 600 mm (Aluminum Arch) 750 x 575 mm (Iron Arch Cover)	600 x 400 mm (Aluminum Arch)	800 x 600 mm (Aluminum Arch Cover)(Standard)	600 x 400 mm (Aluminum Arch Cover)(Standard)
Power Supply	110/220V/1 Phase, 220V/380V/415V 3 Phase			
Strap Cycle Speed	30-32 Cycles / Min. (60 Hz)	34-36 Cycles / Min. (60 Hz)	32-35 Cycles / Min. (60Hz) (It depends on the package size and special requirements)	34-37 Cycles / Min. (60Hz) (It depends on the package size and special requirements)
Dimension (WxDxH)	1240 x 580 x 1475 mm	1040 x 580 x 1275 mm	1240 x 625 x 1465 (Standard)	1040 x 625 x 1265 (Standard)
Strap Width	6-15mm (Change kits and adjustment)	6-15mm (Change kits and adjustment)	6-15 mm (Change kits and adjustment)	6-15 mm (Change kits and adjustment)
Tension Strength	5-75 kg	5-75 kg	5-75 Kg	5-75 Kg
Table Height	805 mm	805 mm	795 mm	795 mm
Available Packing Size (WxH)	100-750 x 30-575 mm (Aluminum Arch) 100-700 x 30-550 mm (Iron Arch Cover)	100-550 x 30-375 mm	100-750 x 30-550 mm	100-550 x 30-350 mm
Net Weight	190 kg	170 kg	Approx. 200 Kg	Approx. 170 Kg
Sealing Method	Heat Sealing			

Model	M-60AXN5 Big Arch	M-60AXPB-2HT	M-60AXPR-3HT	M-60AX900D
Arch Size (WxH)	1250 x 500 mm (Iron Arch Cover)(Standard)	750 x 565 mm (Iron Arch Cover) (Standard)	1150 x 375 mm (Iron Arch Cover) (Standard)	760 x 400 mm (Aluminum Arch)
Power Supply	110V/220V/1 Phase, 220V/380V/415V 3 Phase			
Strap Cycle Speed		25-27 Cycles / Min. (60 Hz) (It depends on the package size)	25-27 Cycles / Min. (60Hz) (It depends on the package size)	30 Cycles / Min. (60Hz) (It depends on the package size)
Dimension (WxDxH)	1490 x 625 x 1410 mm	1240 x 640 x 1470 mm(Standard)	1640 x 640 x 1285 mm	900 x 640 x 1300 mm
Strap Width	5 mm	6-15 mm (Change kits and adjustment)		
Tension Strength	5-75 Kg	5-75 kg	5-75 kg	5-75 kg
Table Height	830 mm	810 mm	823mm	830 mm
Available Packing Size (WxH)	100-1150 x 30-450 mm	250-500 x 30-450 mm	250-800 x 30-250 mm	L160 x W80 x H120 mm (with #32 tiny slide table)
Net Weight		247 kg	300 Kg	200 Kg
Sealing Method	Heat Sealing			

Model	M-60AX940	M-60AX940D	M-60AXPB-AP-2HT	M-60AXPR-2HT
Arch Size (WxH)	800 x 600 mm (Aluminum Arch Cover)(Standard)	750 x 575 mm (Iron Arch Cover)	750 x 565 mm (Iron Arch Cover)(Standard)	750 x 575 mm (Iron Arch Cover)(Standard)
Power Supply	110/220V/1 Phase, 220V/380V/415V 3 Phase			
Strap Cycle Speed	30 Cycles / Min. (60Hz) (It depends on the package size)	30 Cycles / Min. (60Hz) (It depends on the package size)	25-27 Cycles / Min. (60 Hz) (It depends on the package size)	25-27 Cycles / Min. (60Hz) (It depends on the package size)
Dimension (WxDxH)	940 x 640 x 1500 (Standard)	940 x 640 x 1500 (Standard)	1394 x 645 x 1615 mm	1240 x 650 x 1480 mm
Strap Width	6-15mm (Change kits and adjustment)			
Tension Strength	5-75 kg	5-75 Kg	5-75 kg	5-75 Kg
Table Height	830 mm	830 mm	810 mm	815 mm
Available Packing Size (WxH)	100-700 x 30-500 mm (Aluminum Arch Cover)	100-650 x 30-450 mm (Iron Arch Cover)	250-500 x 30-450 mm	250-500 x 30-450mm
Net Weight	200 Kg	200 Kg	323 kg	247 Kg
Sealing Method	Heat Sealing			

# M-60 AX SERIES

Auto-Feeding Electronic Tension Adjustment and Retry Function  
Easy Operation

- Innovatory Auto-Feeding System
- Auto Positioning and Retry Function
- Jam-Free and Electronic Tension
- Patent Aluminum Arch
- Internal Foot Pedal System

